

Resistance and Conductance Worksheet

1. The electric current passing through a resistor has been measured for different voltages. The following graph shows the results.

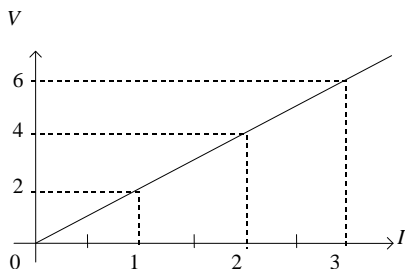

What is the value of the resistance of the resistor?

- A) 2Ω B) 0.5Ω C) 10Ω D) 90Ω
2. Varying the potential difference between 0 and 9 volts you measure the current through a nichrome wire, gauge 26 and length 50 cm. Your results are shown in the table below.

POTENTIAL DIFFERENCE (V)	CURRENT (A)
0.0	0.00
1.5	0.35
3.0	0.70
4.5	1.00
6.0	1.40
7.5	1.70
9.0	2.00

Draw a resistance graph of the current (I) as a function of the potential difference (V) and find the resistance of the resistor.

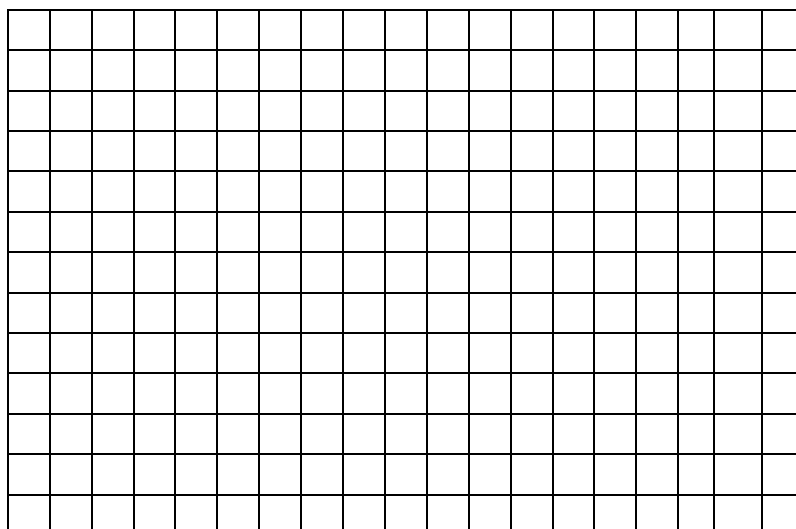

3. The following table shows measurements related to four different resistors.

Resistor	Potential Difference (V)	Current Intensity (A)
1	10	10
2	10	1
3	1	10
4	4	2

Which of the above resistors has the least resistance?

- A) Resistor 1 B) Resistor 2 C) resistor 3 D) resistor 4

4. A student was asked to vary the current intensity in this circuit and to measure the potential difference (voltage) across the terminals of each resistor for each value of I_t .

The student made the following observations:

I_t (A)	V_1 (V)	V_2 (V)
1	3	5
3	6	10
5	9	15
7	12	20

- A) For each resistor, draw a **graph** showing current intensity I as a function of the potential difference (voltage) V across the terminals of that resistor.
 B) Calculate the resistance of each graph in order to determine the resistance of each resistor.
 C) Given this data and using graphs, determine which resistor has the least conductance.

5. Which of the following substances best conducts electricity?



- A) Copper B) Water C) Nichrome D) Plastic

6. The outer covering of your radio's electrical cord is made of rubber. Which of the following properties best explains why rubber is used in this way?

- A) It is a good insulator. C) It is malleable.
 B) It is lightweight. D) It is resistant to corrosion.

7. Technicians are working on a device that includes an electrical circuit that must be built with the best electrical conductor. The following table gives the characteristics of four wires. One of these wires must be chosen to build this circuit.

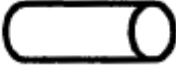
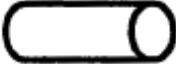
CHARACTERISTICS OF FOUR ELECTRIC WIRES

Electric Wire	Characteristics	
	Type of Wire	Thickness of Wire
1	nichrome	
2	copper	
3	nichrome	
4	copper	

Which one of these wires should the technicians use?

- A) Wire 1 B) Wire 2 C) Wire 3 D) Wire 4
8. Bob is debating which extension cord would be the best to plug in his electric lawnmower. Extension cord A has a length of 5 m, whereas extension cord B has a length of 10 m. Which of the following choices correctly matches the optimal extension cord with correct scientific justifications?

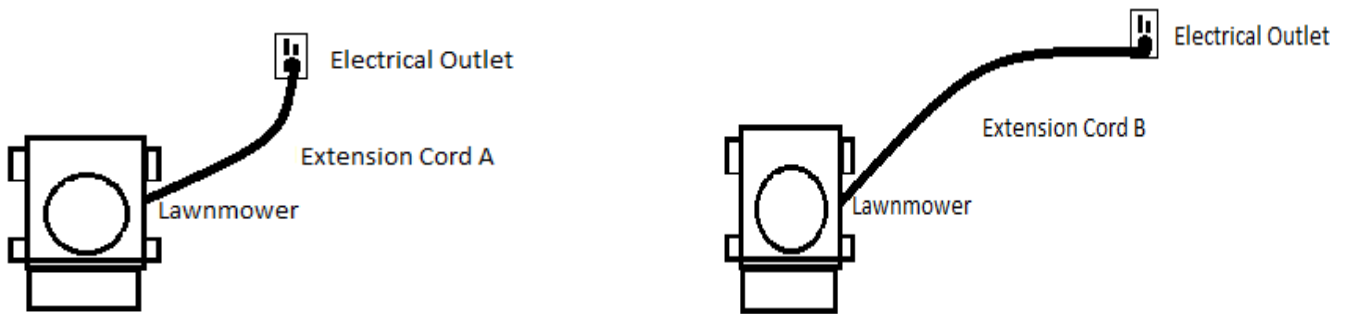

- A) Extension cord A, the lawnmower will have more power because the resistance is higher due to its length
- B) Extension cord A, the lawnmower will have more power because the resistance is lower due to its length
- C) Extension cord B, the lawnmower will have more power because the resistance is higher due to its length
- D) Extension cord B, the lawnmower will have more power because the resistance is lower due to its length